



▲ Model 115-3



The Model 115-3 has a wide range of applications: anywhere it may be required to position a valve electrically.

Typical examples include:

- ▶ Process control
- ▶ Supervisory flow or pressure control
- ▶ Fuel terminal loading racks

SERIES FEATURES

- ▶ Electrically operated solenoids enable the valve to be opened, closed, or held in any position
- ▶ Can be maintained without removal from the line
- ▶ Independently adjustable opening and closing speeds
- ▶ Factory tested and can be pre-set to your requirements

OPERATION

Two two-way solenoids operate the Model 115-3. The first connects the main valve inlet to the diaphragm chamber and, when it is open, causes the main valve to close. The second solenoid connects the diaphragm chamber to the main valve outlet and, when it is open, allows the main valve to open. A needle valve is installed in series with each solenoid, giving separate adjustment of the valve opening and closing speeds.

The solenoids can be supplied to give one of the following "default" modes on absence or loss of electrical power:

- Default to closed
- Default to open
- Default in last position

COMPONENTS

The Model 115-3 consists of the following components, arranged as shown on the schematic diagram:

- 1.) Model 65 Basic Control Valve (Fail Closed)
- 2.) Model 450 Two-Way Solenoid Pilot
- 3.) Model 451 Two-Way Solenoid Pilot
- 4.) Model 141-2 Needle Valve
- 5.) Model 123 Inline Strainer
- 6.) Model 155L Visual Indicator (Optional)

SCHEMATIC

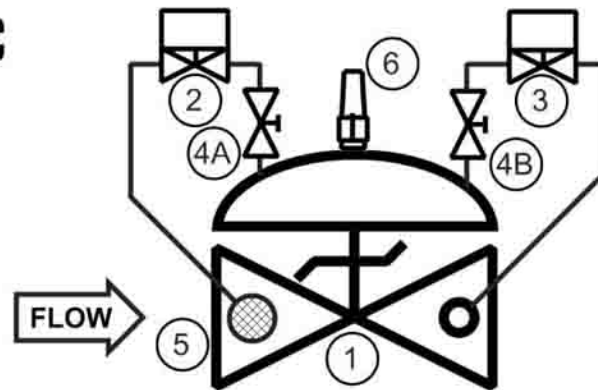

RECOMMENDED INSTALLATION

- ▶ Install the valve with adequate space above and around the valve to facilitate servicing. Refer to the Dimension Table.
- ▶ Valve should be installed with the bonnet (cover) at the top, particularly 8" (DN200) and larger valves, and any valve with a limit switch.
- ▶ Shut-off valves should be installed upstream and downstream of the control valve. These are used to isolate the valve during start-up and maintenance.
- ▶ Following main valve installation, the solenoid must be wired into the user's control system. This is a simple two-wire (plus ground) connection.

SIZING

Definitive sizing information can be found in the Series 115 section of the OCV Catalog and Engineering section Performance Charts. Consult the factory for assistance.

MAX. PRESSURE

Note: Working pressures of solenoids vary greatly, consult factory on application of OCV Model 115-3 valves.

END CONNECTIONS	DUCTILE IRON	STEEL WCB	STEEL LCB	Stn.Stl. CF8M	ALUMINUM
Threaded	44.1 bar	44.1 bar	44.1 bar	44.1 bar	19.7 bar
Grooved	20.7 bar	20.7 bar	20.7 bar	20.7 bar	13.8 bar
150# Flanged	17.2 bar	19.7 bar	18.4 bar	19.0 bar	19.7 bar
300# Flanged	44.1 bar	51.0 bar	48.0 bar	49.6 bar	---

SIZES

GLOBE/ANGLE

Screwed Ends: 1 1/4" - 3" (DN32 thru DN80)

Grooved Ends: 1 1/2" - 6" (DN40 thru DN150)

Flanged Ends:

1 1/4" - 24" (DN32 thru DN600) (globe);

1 1/4" - 16" (DN32 thru DN400) (angle)

TEMPERATURE RANGE

(Valve Elastomers)

Buna-N -40°C - 82°C

Viton -17°C - 204°C

MATERIALS

Consult factory for others.

Body/Bonnet: Ductile Iron (epoxy coated), Carbon Steel (epoxy coated), Stainless Steel, Aluminum

Seat Ring: Stainless Steel, Bronze

Stem: Stainless Steel, Monel

Spring: Stainless Steel

Diaphragm: Buna-N, Viton, (Nylon reinforced)

Seat Disc: Buna-N, Viton

Pilot: Stainless Steel, Bronze

Other pilot system components:

Stainless Steel, Bronze/Brass

Tubing & Fittings: Stainless Steel, Copper/Brass

SOLENOID

Enclosure: Explosion Proof NEMA 4X, 6P, 7, 9

Body: Stainless Steel, Brass

Voltages: 24, 120, 240, 480 VAC

12, 24 VDC

Note: Working pressures of solenoids vary greatly, consult factory on application of OCV Model 115-3 valves.

SPECIFICATIONS

(Typical Fuel Application)

The solenoid control valve shall operate by means of discrete electrical signals. The valve shall be equipped with two two-way solenoid valves that will allow the valve to be opened, closed, or held in any intermediate position. The solenoids shall be configured so that the valve will <open, close, hold position> on loss of electric power.

DESIGN

The solenoid valve shall be a single-seated, line pressure operated, diaphragm actuated, pilot controlled globe valve. The valve shall seal by means of a corrosion-resistant seat and a resilient, rectangular seat disc. These, and other parts, shall be replaceable without removing the valve from the line. The stem of the main valve shall be guided top and bottom by integral bushings. Alignment of the body, bonnet and diaphragm assembly shall be by precision dowel pins. The diaphragm shall not be used as a seating surface, nor shall the pistons be used as an operating means. The pilot system shall be furnished complete and installed on the main valve. It shall include two needle valves, an inline strainer and two solenoid valves. The solenoid control valve shall be operationally and hydrostatically tested prior to shipment.

MATERIALS OF CONSTRUCTION

The main valve body and bonnet shall be ductile iron per ASTM A536, Grade 65-45-12. All ferrous surfaces shall be coated with 4 mils of epoxy. The main valve seat ring shall be CF8M stainless steel. Elastomers (diaphragms, resilient seats and O-rings) shall be Buna-N. The needle valve and control line tubing shall be stainless steel. The solenoid valves shall have stainless steel bodies, explosion-proof enclosures and be suitable for operation on <voltage>.

OPERATING CONDITIONS

The solenoid control valve shall be suitable for pressures of <X to X> bar at flow rates up to <X> m³/hr.

ACCEPTABLE PRODUCTS

The solenoid control valve shall be a <size> Model 115-3, <globe pattern, angle pattern>, with <150# flanged, 300# flanged, threaded, grooved> end connections, as manufactured by OCV Control Valves, Tulsa, Oklahoma, USA.

METRIC DIMENSIONS - M.M.

DIM	END CONN.	DN32-DN40	DN50	DN65	DN80	DN100	DN150	DN200	DN250	DN300	DN350	DN400	DN600
A	SCREWED	222	251	267	330	--	--	--	--	--	--	--	--
	GROOVED	222	251	267	330	387	508	--	--	--	--	--	--
	150# FLGD	216	238	267	305	381	451	645	756	864	991	1026	1575
	300# FLGD	222	251	283	324	397	473	670	791	902	1029	1067	1619
C	SCREWED	111	121	152	165	--	--	--	--	--	--	--	--
	GROOVED	111*	121	152	165	194	--	--	--	--	--	--	--
	150# FLGD	108	121	152	152	191	254	322	378	432	--	529	--
	300# FLGD	111	127	162	162	198	267	335	395	451	--	549	--
D	SCREWED	79	98	102	114	--	--	--	--	--	--	--	--
	GROOVED	79*	98	102	114	143	--	--	--	--	--	--	--
	150# FLGD	76	98	102	102	140	152	203	289	279	--	398	--
	300# FLGD	79	105	111	111	148	165	216	306	298	--	419	--
E	ALL	152	152	178	165	203	254	302	391	432	457	483	686
F	ALL	98	98	98	98	98	98	162	162	162	162	162	203
H	ALL	254	279	279	279	305	330	356	432	457	508	508	724

*GROOVED END NOT AVAILABLE IN DN32

CE Markings

Applies to fuel valves installed in the European Union in accordance with the Pressure Equipment Directive, 97/23/EC

CE-marked valves are available in LCB steel and CF8M stainless steel only

OCV is registered to the PED through Det Norske Veritas

The following valves will be CE-marked:

- 6" (DN150) and larger valves, 150# and 300# class, liquid fuel only
- 2" (DN50) thru 4" (DN100) valves, 300# class, liquid fuel
- 1 1/4" (DN32) thru 4" (DN100) valves, 300# class, LPG or Butane service
- 4" (DN100) and smaller valves in Class 150# (liquids) are furnished under SEP with no CE-mark

For maximum efficiency, the OCV control valve should be mounted in a piping system so that the valve bonnet (cover) is in the top position. Other positions are acceptable but may not allow the valve to function to its fullest and safest potential. In particular, please consult the factory before installing 8" (DN200) and larger valves, or any valves with a limit switch, in positions other than described. Space should be taken into consideration when mounting valves and their pilot systems.

A routine inspection & maintenance program should be established and conducted yearly by a qualified technician. Consult our factory @ **1-918-627-1942** for parts and service.

How to order your Model 115-3 valve

When ordering please provide:

Fluid to be controlled - Model Number - Size - Globe or Angle - End Connection - Body Material - Trim Material - Solenoid Voltage - Energize to Open or Close Valve - Special Requirements / Installation Requirements - Power failure mid open/close/hold last position

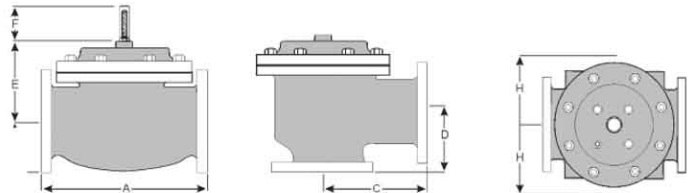

QUALITY SYSTEM
REGISTERED TO
ISO 9001

phone: (918)627.1942 • fax: (918)622.8916 • 7400 East 42nd Place, Tulsa, Oklahoma 74145
email: sales@controlvalves.com • website: www.controlvalves.com