

NoMix 2000 System Variations

The individual modules are connected via a standard 4-core shielded cable (2 cores for power supply, 2 cores for the bus system, shield for mechanical protection purpose only). There is no predetermined sequence for connecting more than 20 modules.

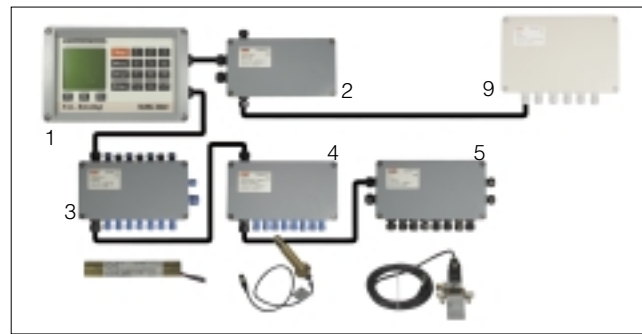

Version 1
NoMix 2000
Standard

Version 2
NoMix 2000
with Seal-Parcel-Delivery
(MultiSeal SPD)

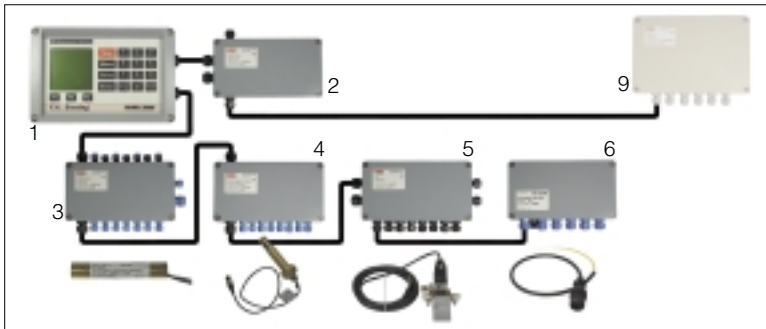

Version 3
NoMix 2000
with overfill prevention
amplifier

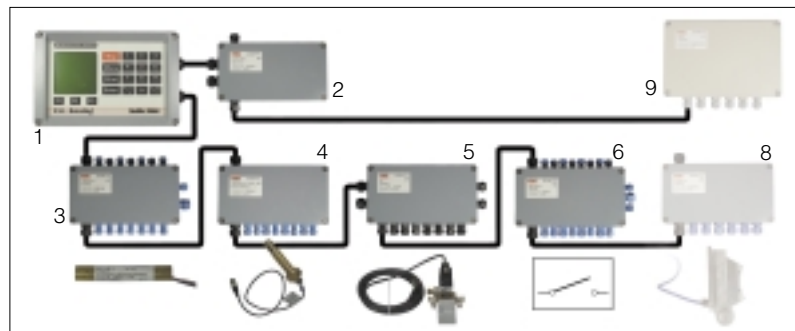

Version 4
NoMix 2000
with overfill prevention
amplifier and
Seal-Parcel-Delivery
(MultiSeal SPD)

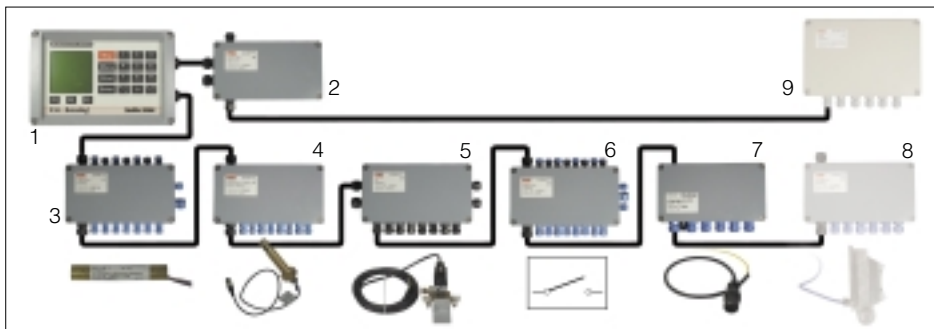

Description	Dimensions W x H x D (mm)	Weight (kg)	Description	Dimensions W x H x D (mm)	Weight (kg)
1 Man-Machine Interface	240 x 160 x 120	2,8	6 SPD Sensor Interface	220 x 120 x 80	2,2
2 Main controller	220 x 120 x 80	2,2	7 Overfill Prevention Amplifier	220 x 120 x 80	2,7
3 TAG-Interface	220 x 120 x 80	2,2	8 Hall Sensor Interface	220 x 120 x 80	2,2
4 Wetleg Sensor Interface	220 x 120 x 80	2,2	9 EMIS Communication Interface	240 x 160 x 120	2,5
5 Valve Control Interface	220 x 120 x 80	2,7			

Headoffice and Factory
F.A. Sening GmbH
Regentstrasse 1
25474 Ellerbek Germany
Phone: +49-4101-304-0
Fax: +49-4101-304-255
E-Mail fa_sening@fmc.com

Sales Office:
Smith Meter Inc.
Ambassador House
181, Famham Road
Slough SL1 4XP, Berkshire, England
Phone +44-1753-571515
Fax +44-1753-529966



Quality-Management-System approved to ISO 9001.

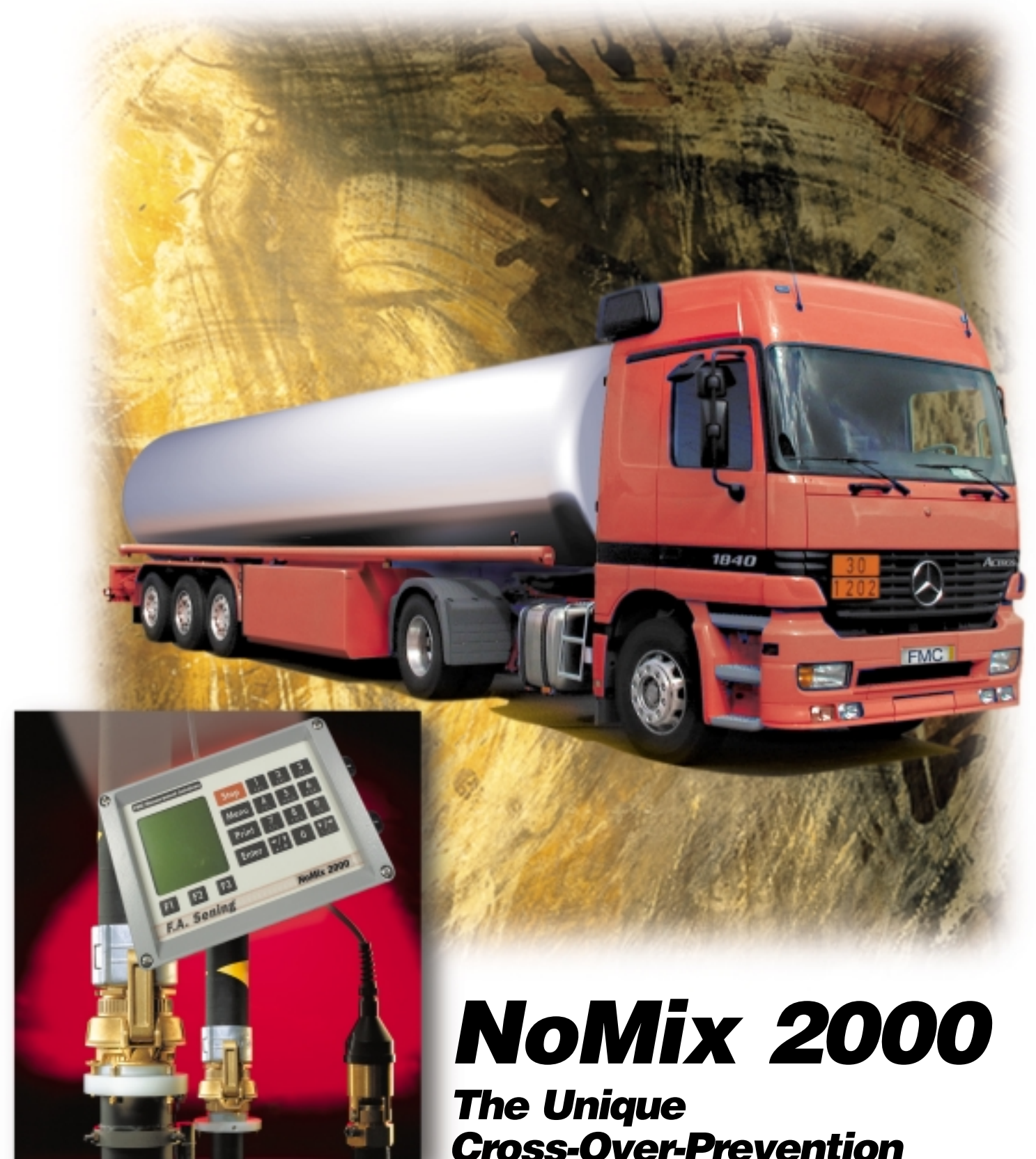

P02051 – 9/2000 Subject to technical modification without prior notice

NoMix 2000
The Unique
Cross-Over-Prevention
System

What is the NoMix 2000 Cross-Over-Prevention System

By Cross-Over-Prevention System a system is meant that fulfils both the cross-over-prevention and safety requirements of tank trucks for gasoil and gasoline deliveries to service station.

The Cross-Over-Prevention System incorporates both the loading and delivery sites and operates so intelligently as not to require any additional operation of the tank truck driver beyond his normal tasks of e.g. making the hose connections.

The Cross-Over-Prevention System relieves the driver and allows the tank truck to be utilized more efficiently.

The **NoMix 2000** Cross-Over-Prevention System works automatically, in a supportive manner as a "shadow system" in the background. It only intervenes in case of incorrect operation, e.g. when the wrong product is going to be loaded or dispensed. The system then prevents the operation to be started and enables the driver to take corrective action prior to expansive errors.

The basis for the overall functionality of **NoMix 2000** is a passive product recognition device (non-volatile electronic memory) at the loading and delivery stations, which are called TAGs.

The TAGs store, as minimum information, the product type and a unique serial number. **NoMix 2000** reads these data by utilising the conductive loop created with the electrically conductive loading arms and vapour return and product discharge hoses.

As **NoMix 2000** takes over all control tasks at the tank truck, for instance the opening and closing of footvalves and discharge valves as well as the monitoring of the wetleg sensors, the required logical associations can be carried out.

For example, **NoMix 2000** automatically assigns the loaded product to the connected compartment and checks during discharge that the product type for the connected service station tank is consistent.

As the TAG technology has proven itself for many years in a wide range of application, it will in future become the European standard for product recognition.

Appearing below the schematic diagram of the loading and discharge procedure by a tank truck with **NoMix 2000** and loading arm TAG installation.

Loading Mode

Connecting the conductive loading arm and vapour hose creates a current loop through which the **NoMix 2000** reads the passive TAGs.

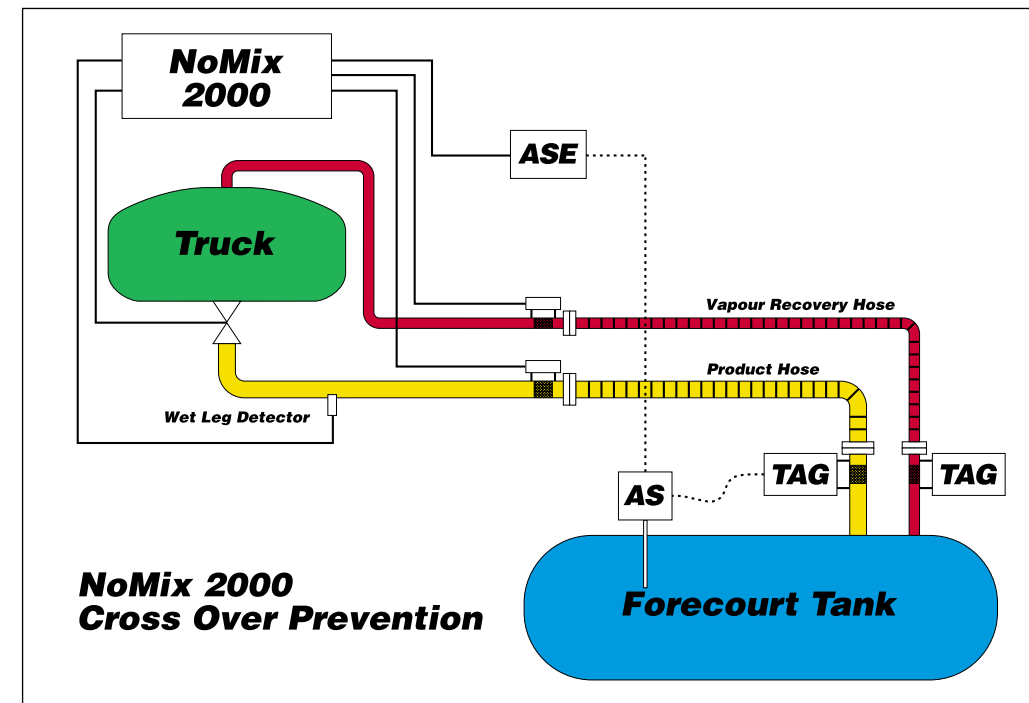
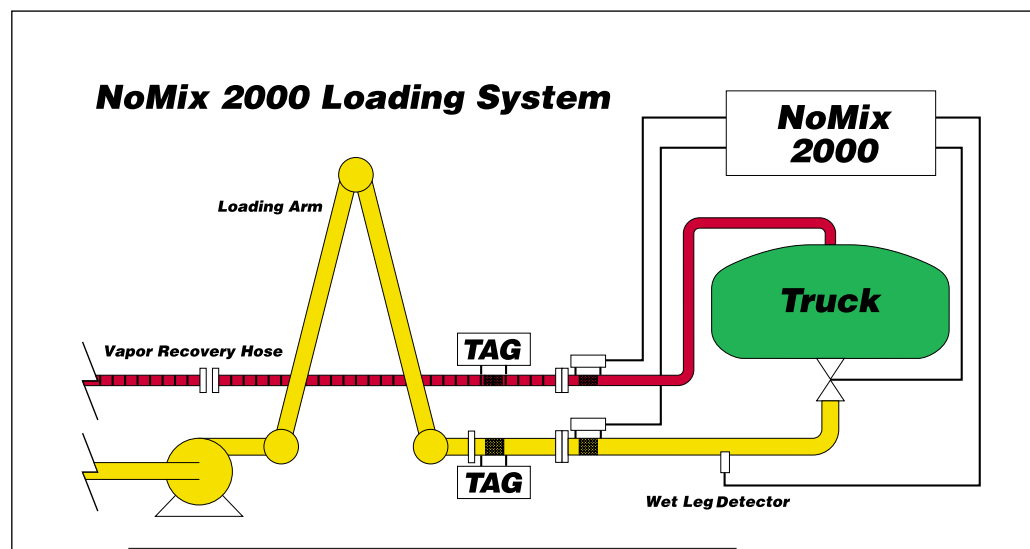

Discharge Mode

Connecting the conductive product and vapour hose creates a current loop through which the **NoMix 2000** reads the passive TAGs.

Installation of overfill prevention is optional.

What is NoMix 2000

NoMix 2000 is the consistent and future-orientated enhancement of the market-leading **NoMix** Cross-Over-Prevention System.

NoMix 2000 offers the maximum synthesis of functionality, features, compatibility, flexibility, expandability and cost.

NoMix 2000 is modular and has a network architecture. All individual modules communicate with each other on a communication bus. This enables the simplest possible assembly of the individual modules, and thus of the desired features. Subsequently, **NoMix 2000** can be easily and cost-effectively expanded with other features.

Naturally, **NoMix 2000** can also be employed as a true Sealed-Parcel-Delivery System.

The EMIS open interface is available for connection to external processing electronics, e.g. an on-board computer.

What does NoMix 2000 offer

Thanks to its intelligent and modular construction, as well as its multiplicity of features combined with functionality, **NoMix 2000** fulfils all requirements for a universal, cost-effective future-orientated Cross-Over-Prevention System.

Depending on the installed **NoMix 2000** modules, the following features can be implemented:

- Product identification
- Overfill prevention at the service station
- Cross-over-prevention
- Empty compartment verification
- Hose supervision
- Sealed-Parcel-Delivery
- Valve control
- Pipework monitoring

NoMix 2000 can be implemented for semitrailers and for rigid trucks with drawbar trailers. There is no difference whether gravity discharge is metered or non-metered or a combination of both.