

GMVZ 1004 Truck Meter Package

The accurate metering system for petroleum tank trucks.

F.A. Sening's meter packages combine the high precision Smith rotary vane volumetric meter with the high efficient Sening special gas extractor technology into an economical solution for metering gasoil and gasoline from road tankers.

The model GMVT1004 meter package covers a wide range of applications for gravity and pressure discharge. Integrated control valves support the requirements for compact and light weight components on road tankers, thus improving the performance of the vehicle.

The Sening truck metering system integrates a compact and high performance flowmeter with an intelligent flowcomputer **MultiFlow** and the **ADD** additive injection pump into a high efficient and economic package for gasoline and heating fuel tank trucks.



Advantages

- Compact and light weight design
- Simple "plug and play" type installation and operation
- Integrated pulse transmitter for **MultiFlow** flowcomputer (or other available brands, consult factory for more details)
- Integrated discharge valves for up to 2 wet-hoses and 2 dry-hoses
- Electronic hose selection and valve control via **MultiFlow** flowcomputer
- Simple calibration supported by **MultiFlow** flowcomputer
- High precision and high performance Smith rotary vane metering element
- Low pressure drop and excellent flowrate performance
- Pressure **and** gravity discharge mode
- Closed metering element, no mechanical seal, low maintenance
- High efficient special gas extractor with integrated strainer for meter protection

Technical data

Smith rotary vane positive displacement meter combined with Sening special gas extractor.

- Flowrate: 100 to 1600 l/min⁻¹
- Accuracy: +/- 0,15%
- Viscosity: max. 20 mPas
- Operating pressure: max. 10 bar
- Temperature range: -10 to +50°C
- Air supply: 3 to 7,5 bar
- Materials of construction: Aluminum, stainless steel, brass, Viton, NBR
- Weight: about 68 kg
- Approvals: TÜV
- Certifications: PTB (other approvals pending)

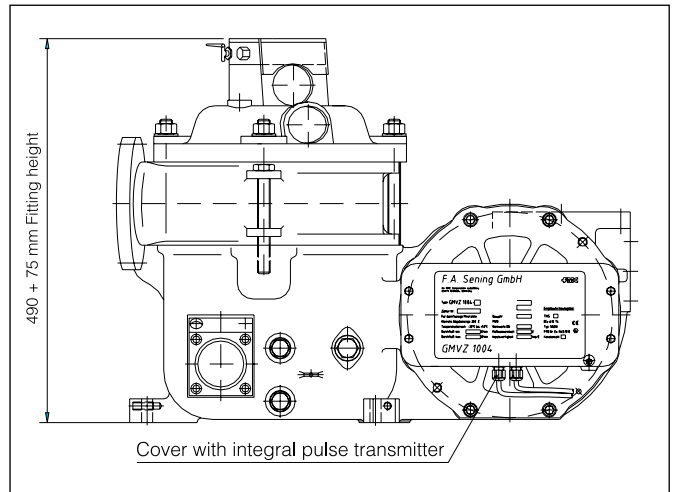
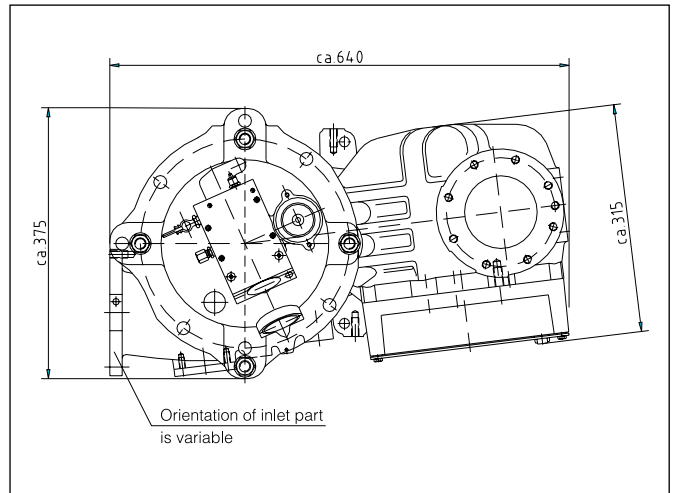

Headoffice and Factory
F.A. Sening GmbH
 Regentstrasse 1
 25474 Ellerbek
 Germany
 Phone: +49-4101-304-0
 Fax: +49-4101-304-255
 E-Mail fa_sening@fmc.com

Sales Office:
Smith Meter Inc.
 Ambassador House
 181, Farnham Road
 Slough SL1 4XP, Berkshire, England
 Phone +44-1753-571515
 Fax +44-1753-529966



Quality-Management-System approved to ISO 9001.