

HC900 Controller for Feed Water Heater Control

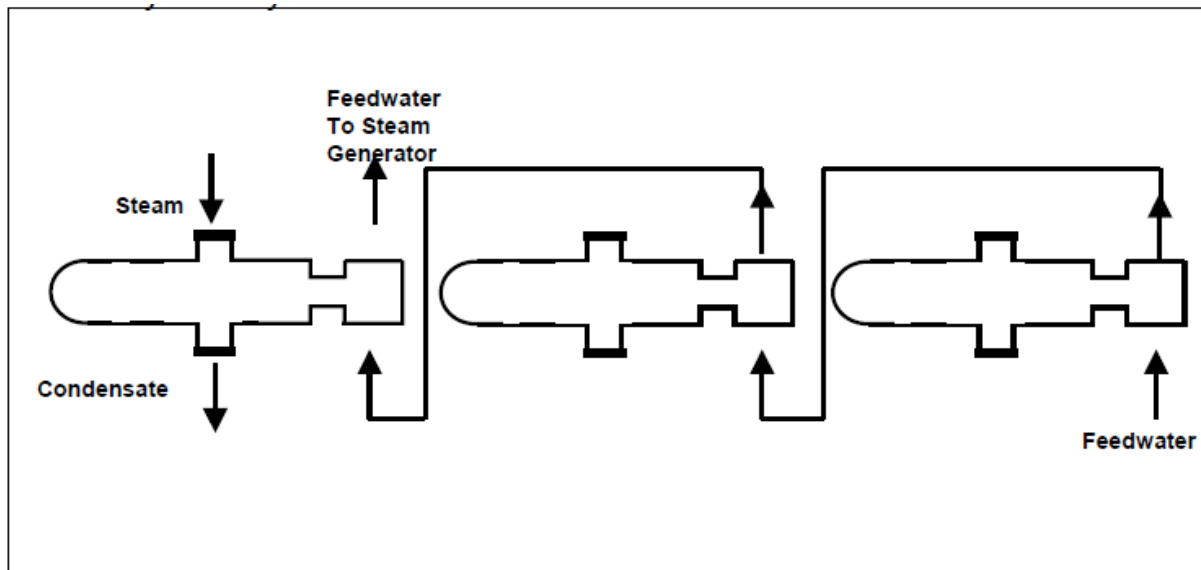

Problem

Several conditions influence feed water heater operation and cause various inefficiencies and problems. Feed water level is one such condition.

If the level in a heater is maintained at a point higher than optimum, the excess water submerges the lower rows of tubes, decreasing condensing efficiency. At best, this causes no damage but does reduce thermal performance and increases fuel consumption. At worst, high level provides a means for water induction into the turbine, a leading cause of forced outages.

If the level in a heater is maintained at a point lower than optimum, the insufficient water may cause leaks, heater damage and shortened heater life. Low level also results in steam entering the drain cooler section or flashing, leading to several types of damage:

- Tube erosion impeding proper water flow required to sustain full load operation

- Tube damage (leaks, breaks) from vibration caused by increased steam velocities
- Erosion or breaching of divisions between cooler and condenser zones

Feedwater flows through a string of heaters, being heated by steam extracted from the turbine. Each heater operates at increasing temperature and pressure as feedwater flows towards the steam generator. Steam is condensed in the heaters, and the level of water in the bottom of the heater must be controlled.

In normal operation, the level in each heater is measured by a differential pressure transmitter. Level is controlled to setpoint by modulation of a drain flow valve that passes flow to the preceding heater. If a drain valve is fully open and level remains high, the control will begin to divert drain flow directly to the condenser. It is important that the heater not become flooded, increasing the possibility of water reaching the turbine, so there is normally an overriding level switch which closes a valve in the extraction line to the heater.

The HC900 Solution

The HC900 Controller provides an ideal solution to the feedwater heater control challenge. This is accomplished through the simple updating of existing controls or through complex strategies with interacting logic and calculations which permit compensation for transient conditions such as load changes or equipment failures.

The common database for analog and digital inputs and outputs, combined with extensive math, alarming, and logic capabilities, permit any simple or complex control strategies to be easily implemented. Changes in control strategies can be easily configured with a minimum of engineering effort.

Benefit Summary

The Honeywell HC900 provides the following benefits when used in feedwater heater level control applications:

- Extensive set of advanced algorithms for maximum process performance
- Ethernet connectivity for easy plant wide integration.
- Extensive equipment diagnostic and monitoring to maximize process availability
- A common configuration tool for both control and OI minimizing engineering costs.
- Auto tuning and fuzzy overshoot protection for quick startup and proper control operation

Implementation

Overview. The HC900 Controller as shown in Figure 2 consists of a panel-mounted controller, available in 3 rack sizes along with remote I/O, connected to a dedicated Operator Interface (OI).



Figure 2: HC900 Controller, 900 Control Station OI and Hybrid Control Designer Software

All field signals terminate at the controller. The controller has universal analog inputs, analog outputs and a wide variety of

digital input and output types. This controller will provide all the feedwater heater control functions.

Configuration. The Hybrid Control Designer tool provides advanced configuration techniques allow a variety of strategies to be easily implemented. The run-mode configuration monitoring and editing capability allows these strategies to be tested and refined as process knowledge is gained.

Monitoring : The complete operation can be monitored and controlled from the easy to use, familiar displays of the 900 Control station (as shown in Fig.3) which allows easy drag and drop of displays.

- 900 Control Station has 10" or 15" touch screen display
- Contains pre-defined display features and custom display development tools
- Has color display and touch panel user interfaces that enhance process monitoring and simplifies online controller changes
- Uses Station Designer software for configuration and Works with HC900 Control Designer software to create control station database that is imported from HC900 controller

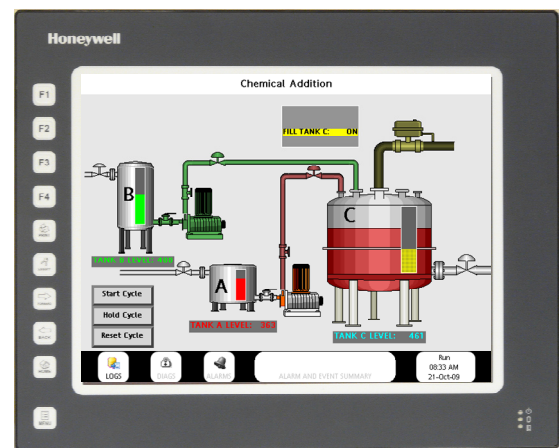

Figure 3: 900 Control Station OI (15")

HMI and SCADA through Experion HS and HC900

Experion HS is a powerful software platform that incorporates innovative applications for Human Machine Interface (HMI) and Supervisory Control and Data Acquisition (SCADA). It is comprised of a subset of Honeywell's Experion PKS components and is specifically packaged to provide a targeted and robust system for small to medium automation projects.

Data Storage: The data storage feature of the 900 Control Station can be used to record process information during operation to an expandable compactflash card slot which has protected access behind the panel and it allows for increased data logging capacity with history, the optional flash memory card will also help with screen printing, web access to data, FTP transfers, and custom web page support.

Open Connectivity Over Ethernet. Use popular HMI, data acquisition, OPC server, and HC900's HC Designer configuration software over an Ethernet LAN concurrently to access HC900 controllers via Modbus/TCP protocol.

Peer to Peer Communications. Any HC900 can support up to 32 peer controllers for exchange of analog or digital data over Ethernet.

More Information

For more information on HC900, visit www.honeywellprocess.com, or contact your Honeywell account manager.

Automation & Control Solutions

Process Solutions
Honeywell

1250 West Sam Houston Parkway South
Houston, TX 77042

Lovelace Road, Southern Industrial Estate
Bracknell, Berkshire, England RG12 8WD

Shanghai City Centre, 100 Junyi Road
Shanghai, China 20051